

**YELLO**<sup>TM</sup>  
EQUIPMENT



# PRECISE POWER

CONSISTENTLY STRONG.  
REMARKABLY VERSATILE.

CONSTRUCTION MACHINERY



**CRAWLER EXCAVATOR**  
**SY215C** **SANY**  
Quality Changes the World

Engine  
**CUMMINS QSB6.7**  
Rated power  
**122 kW / 2300 rpm**  
Bucket capacity  
**0.93 m<sup>3</sup>**  
Operating mass  
**22600 kg**



# SANY

**For challenging tasks, you need a first-class partner**

Quality comes from experience. And from new ideas. This is why we combine these two crucial factors at SANY. This is because we are one of the world's leading producers, having sold more than **250 000** excavators in **10 years**. This means that you can always rely on sophisticated products that have been tried and tested in practice. An impressive **5–7%** of our annual turnover is dedicated to research and development. This is why we give you not only our word, but also our extraordinary **five-year warranty** as a guarantee of how powerful and robust our products are.

**250 000**  
EXCAVATORS SOLD IN  
**10 YEARS**

**5–7%**  
TURNOVER FOR RESEARCH  
AND DEVELOPMENT

**FIVE-YEAR  
WARRANTY\***

Quality Changes the World

**CHISELLING  
HAMMERING  
DIGGING  
MOVING  
LIFTING  
LOADING  
DEMOLISHING  
CRUSHING**

\* Applicable in certain markets, please check with your local dealer.

### SY215C HARD FACTS

Max. bucket digging force  
138 kN (ISO)

Max. arm digging force  
102 kN (ISO)

Swingspeed  
10.7 rpm

Max. travel speed  
6 km/h

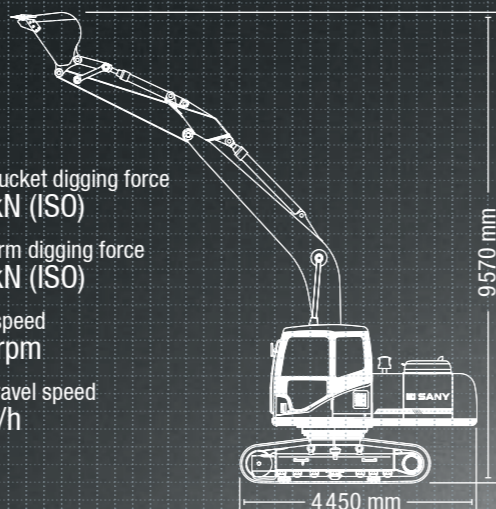

## THE SPECIALIST WHEN IT COMES TO VERSATILITY

With the SANY SY215C crawler excavator, you get more done. No matter where used – it applies its power with precision. This is because every detail is specifically designed for the tough conditions on construction sites. This excavator is a real all-rounder and a specialist in every discipline, from quick loading to precise digging and powerful demolition work.

What particularly sets it apart is its ability to control its tremendous power with great precision – for maximum productivity and therefore a fast return on investment.

**SY215C**

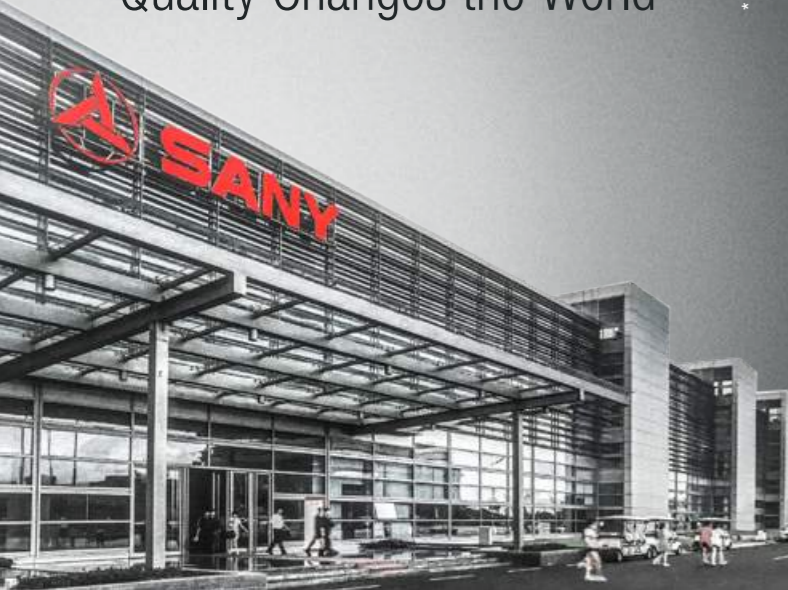



## TOP PROPERTIES

ECONOMY

# IT IS AS LOW IN CONSUMPTION AS IT IS POWERFUL IN PERFORMANCE

The highly efficient engine with common rail technology guarantees excellent performance. Four different operating modes for the various operating conditions precisely adjust the engine and hydraulic power to the requirements. This improves the excavator's response behaviour and ensures lower fuel consumption and reduced emissions.

ECONOMY

## Cost-effectiveness thanks to maximum flexibility

Whether digging, loading, demolishing, transporting, hammering, or performing other tasks, the SANY SY215C tackles a wide range of tasks without compromise – and without long changeover or waiting times. The pre-installed quick-coupler line means that many attachment devices can be fitted.

**SY215C**



## QUALITY

**Durable and robust** – the SY215C can be used whenever the going gets tough. This means that it must be able to withstand a great deal. No problem for the SY215C, as with its reinforced, **extremely robust undercarriage** and particularly clean, **robot-welded seams**, it is exactly the right excavator for hard day-to-day work on construction sites.

## USER EXPERIENCE

**Comfortable workstation** – the cabin of the SY215C leaves nothing to be desired. All of the controls are within easy reach from the air-suspension seat which supports the driver's back. **Maintenance and service support** is also easy to reach: Thanks to the large and easily accessible service doors and clear layout of the most important components, this work is **quick and easy** to complete.

## DIMENSIONS

**Agile power** – the SY215C works through its programme quickly and with great power. This excavator has great power reserves in its 22 tonnes. The machine is mounted on a stable HD undercarriage so that it can be used to the full.



QUALITY

## A very stable foundation

The machines have a great deal of work to do during their tough day-to-day work on construction sites. This is why – from the design stage, to selecting the materials used, quality and conducting the final checks – all excavators by SANY are designed to be robust. For instance, all welded seams are computer-controlled by robots – this maximum precision ensures stability and reliability.

In addition, the robust, wide heavy-duty undercarriage provides a high level of stability. This allows the SY215C to optimally apply its power. Also good to know: All of the access panels are only made from metal.

COMPONENTS

## Improved performance thanks to optimised hydraulics

The position-controlled hydraulic system adjusts the required pressure and oil quantity according to requirements. The powerful, variable piston pumps reach a flow rate of 2 x 222 l/min and therefore achieve a very high level of efficiency at a low engine speed.

## SAFETY

**Safety as a production factor** – it is only possible to work cost-effectively if you work safely. This is why the **large safety package** has everything included as standard, from a travel alarm to the rotating beacon, and from the boom safety valve to the overload warning for lifting and the camera.

## COMPONENTS

**High quality and tried-&-tested** – the water-cooled Cummins diesel engine with common rail technology and AdBlue system guarantees **reliable performance**, even under tough working conditions. The complete package is rounded off by the finely tuned Kawasaki hydraulic system.

## ECONOMY

**Power and efficiency** – the smart hydraulic control system adapts the pump power to the available engine power. This means **greater efficiency** and **lower fuel consumption**, thereby providing excellent **cost-effectiveness**.



## Absolute reliability – for peace of mind!

SANY's five-year warranty\* gives you the assurance that you can fully count on your equipment.

\* With participating partners





DIMENSIONS

# UP TO THE TASK ON EVERY SURFACE

The SY215C's particularly stable heavy-duty undercarriage provides the maximum possible stability. Its welded reinforcements and the use of robust, high-strength steel ensure minimal wear, even when used continually under the maximum load.

The steel chains used also offer the highest quality standard – for a stable foundation on any surface.



### Our highlights – the added benefits SANY offers you:

- + A comfortable driver's cab
- + Fast, powerful hydraulics
- + A clear overview of instruments and display
- + Heavy-duty undercarriage
- + Extensive safety equipment
- + High-quality welded seams
- + ROPS/FOPS-certified



SAFETY

### Best visibility even in poor lighting conditions

Good visibility is required for precise, quick work. In the worst-case scenario, the SY215C itself will provide sufficient lighting. The operating area is illuminated by two LED roof headlamps, two LED headlamps on the boom, one in the superstructure and an LED headlight facing backwards. The high-quality LED lights not only stand out thanks to their particularly good illumination, but also due to their low power consumption and extreme durability, while also being virtually maintenance-free.

USER EXPERIENCE

# THE NEW COMFORT ZONE

For drivers to fully concentrate on their work, they first need to be sitting comfortably. The individually adjustable, air-suspension seat offers a comfortable workstation from which all of the controls are within easy reach. It goes without saying that the multifunctional control levers are located at the centre. This makes it possible to reliably and precisely control the attachment devices, directly relaying the control commands without delay. For even greater comfort: The standard equipment supplied includes the large monitor which can be set to several languages, the automatic climate control system which provides pleasant temperatures even in the summer, the powerful heating, the radio with an additional USB port for the driver's own audio devices and the large storage compartments for everything which the driver needs close to hand.

USER EXPERIENCE

### Minimising maintenance times and maximising operating times

All serviceable components are easily accessible. This means that any maintenance and service support can be carried out efficiently and safely, reducing unproductive downtime and increasing machine availability.

In particular, routine daily checks are quick, simple and safe to perform manually as handrails, anti-slip tread surfaces and an electrical supply for a lamp ensure maximum safety during maintenance work.

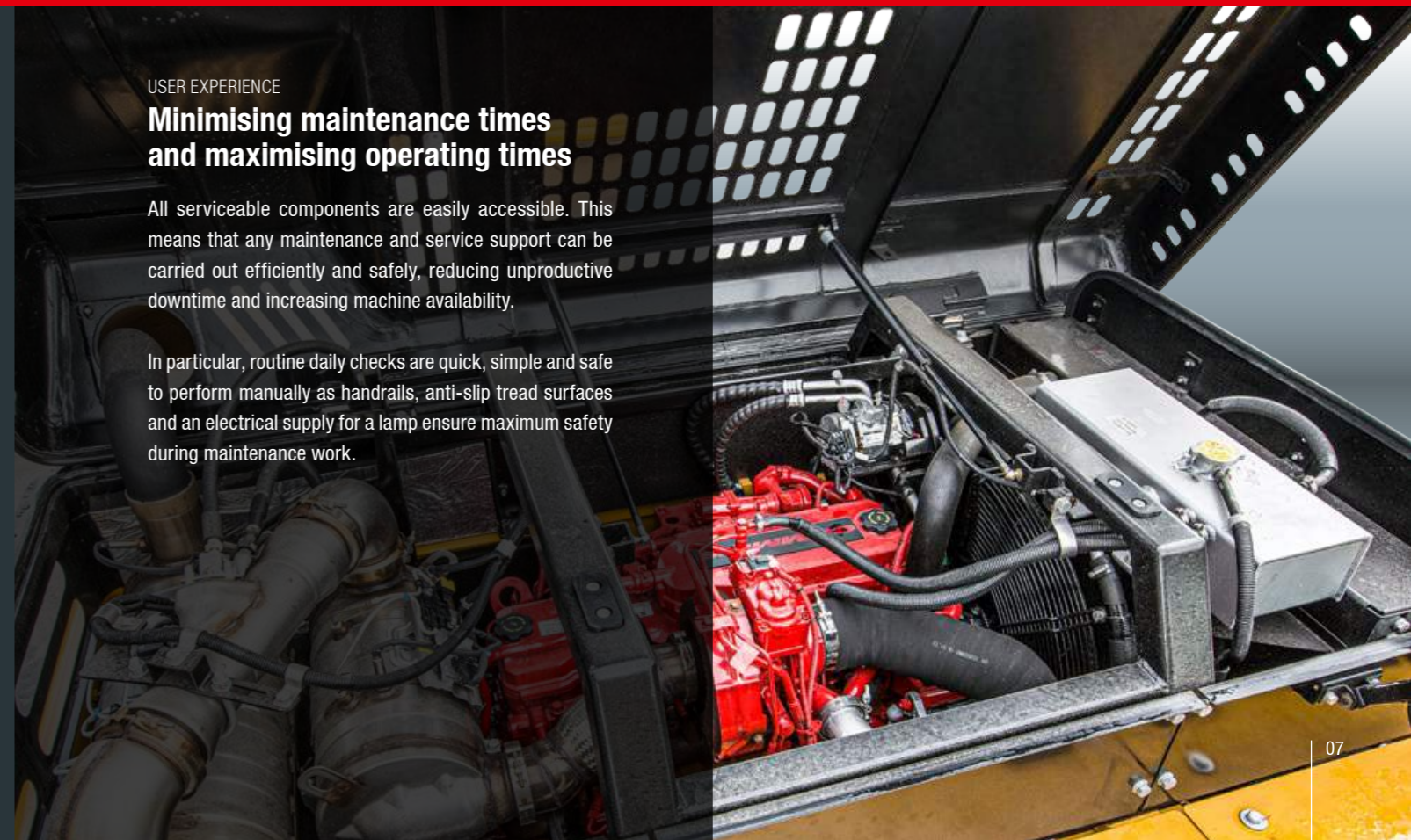



## MOTOR

Model	CUMMINS QSB6.7
Typ	Water-cooled, 6 cylinder, with commonrail and Adblue
Exhaust emissions	Stage IV
Rated power	122 kW / 2300 rpm
Max. torque	732 Nm / 1500 rpm
Displacement	6700 ccm
Batteries	2 × 12 V / 120 Ah

## HYDRAULIC SYSTEM

Mainpump	2 x variable-piston-pump with electronic positive control
Max. oilflow	2 x 222 l/min
Travelmotor	2 speed axial piston motor with planetary reducer and automatic multi-disc brake
Swingmotor	Axial piston motor with planetary reducer and automatic holding brake
Max. oilflow (AUX1)	400 l/min

## RELIEF VALVE SETTINGS

Implement circuit	343 bar
Power boost	373 bar
Swing circuit	275 bar
Travel circuit	343 bar
Pilot pressure	39 bar

## SERVICE REFILL CAPACITIES

Fuel tank	340 l
Engine coolant	27.6 l
Engine oil	27 l
Drive (per side)	5.5 l
Adblue	18,9 l
Hydraulic oil tank	230 l

## PERFORMANCE

Swingspeed	10.7 rpm
Max. travel speed	High 6.0 km/h, slow 3.5 km/h
Max. travel force	208 kN
Gradeability	35°
Bucket capacity	0.93 m <sup>3</sup>
Groundpressure	0.47 kg/cm <sup>2</sup>
Bucket digging force ISO	138 kN
Arm digging force ISO	102 kN

## UNDER AND UPPER STRUCTURE

Boom length	5700 mm
Arm length	2925 mm
Bottomrollers	9
Toprollers	2
Rotation device	Planetary gear reducer driven by an axial piston motor, automatic hydraulic released slewing brake

## OPERATING MASS

SY215C	22 600 kg
--------	-----------

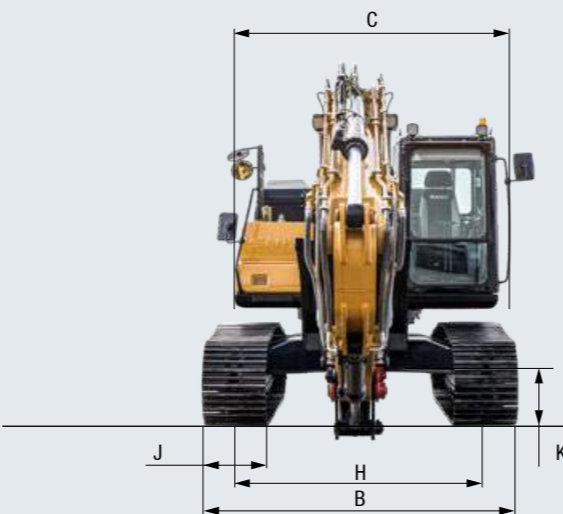

## DIMENSIONS

A Transport length	9728 mm
B Transport width*	2980 mm
C Upperstructure carriage	2710 mm
D Height over cabin/ROPS	2960 mm
E Height of Boom – transport	3370 mm
F Overall length of crawler	4450 mm
G Tail length	2890 mm
H Track gauge	2380 mm
I Track height	923 mm
J Track pads width	600 mm
	700 mm
	800 mm
K Min. ground clearance	480 mm
L Counterweight clearance	1090 mm
M Engine cover height	2630 mm
N Tail swing radius	2890 mm
O Center distance of tumbler	3640 mm

\*at 600 mm track pads width

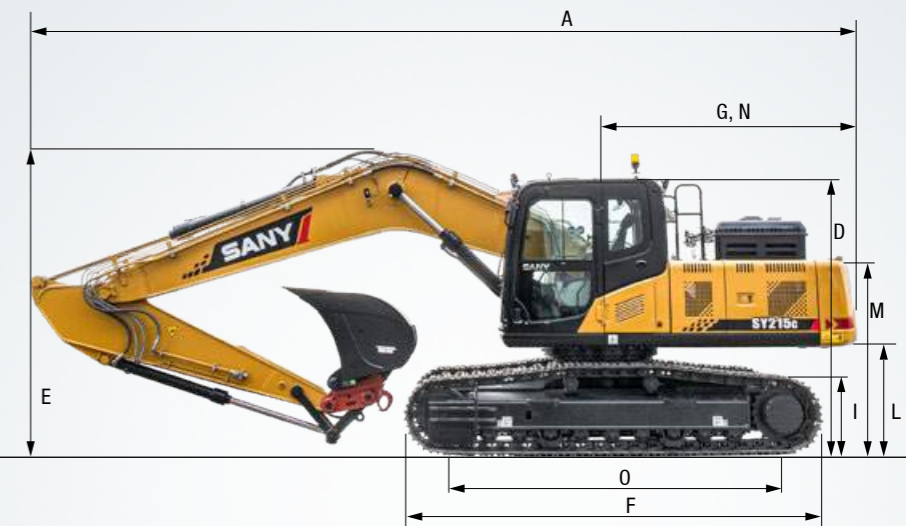

## LIFTING CAPACITIES\*

Load point height	Radius				Max. digging reach							
	3.0m/9.8ft	4.5m/14.8ft	6.0m/19.7ft	7.5m/24.6ft	Capacity	n/ft						
7.5 m kg			4319	4319	3736	3736	6.1					
24.6 ft lb			9522	9522	8236	8236	20.1					
6.0 m kg			4433	4433	3542	3542	7.2					
19.7 ft lb			9773	9773	7809	7809	23.8					
4.5 m kg			4973	4973	4774	3547	7.9					
14.8 ft lb			10964	10964	10525	7820	26.0					
3.0 m kg		7365	7279	5823	4790	4800	3445	3662	2895	8.3		
9.8 ft lb		16237	16047	12838	10560	10582	7595	8073	6382	27.1		
1.5 m kg		9085	6787	6476	4554	4660	3331	3890	2797	8.3		
4.9 ft lb		20029	14963	14277	10040	10274	7344	8576	6166	27.3		
Ground line	kg	6483	6483	9737	6526	6269	4388	4559	3248	4092	2845	8.1
	lb	14293	14293	21466	14387	13821	9674	10051	7161	9021	6272	26.6
-1.5 m kg		10665	10665	9632	6444	6200	4319	4532	3225	4453	3080	7.6
-4.9 ft lb		23512	23512	21235	14207	13609	9522	9991	7110	9817	6790	24.9
-3.0 m kg		14488	12609	9719	6509	6233	4358			5324	3662	6.7
-9.8 ft lb		31941	27798	21427	14350	13741	9608			11737	8073	22.1
-4.5 m kg		12167	12167	8569	6733					7760	5243	5.3
-14.8 ft lb		26824	26824	18891	14844					17108	11559	17.4

\*at 600 mm track pads width

## WORKING AREA

A Max. digging reach	9950 mm
B Max. digging depth	6600 mm
C Max. digging Height	9570 mm
D Max. dumping height	6700 mm
E Min. dumping height	2470 mm
F Max. vertical digging depth	5800 mm
G Overall height over arm by min. swing radius	7680 mm
H Min. swing radius	3730 mm

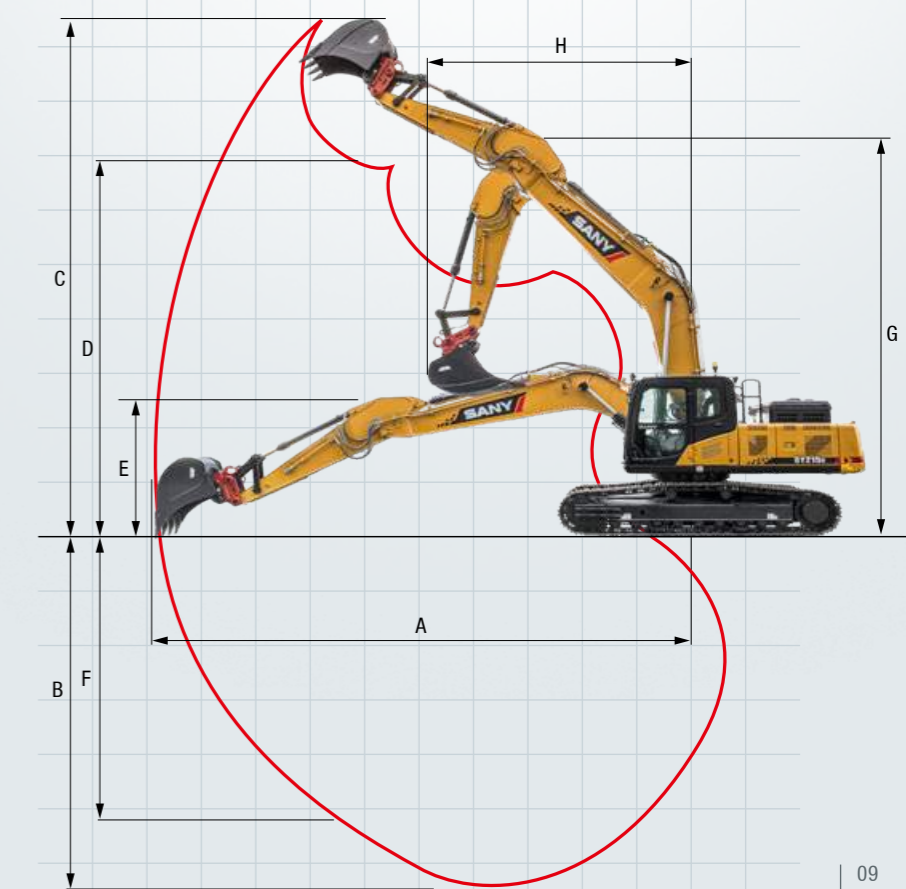

**Versatile power**

With the SANY SY215C, you do not need to worry about additional parts. Everything you need for easy, comfortable work is included as standard.



# A SERVICE YOU CAN RELY ON

Just as we do with our excavators, we also demand high quality and reliability of our service products. This underlines our equipment's performance in terms of their durability and their excellent price-performance ratio. After all, maintenance is crucial

for efficiency, cost-effectiveness and safety. Your SANY dealer is happy to help you with a comprehensive range of services to ensure that your machine continues operating efficiently in the long term.

**OPERATORS COMFORT / CABINE**

Heater	●
Automatic air conditioning C/H	●
Radio and speaker	●
Armrests (adjustable)	●
Airsuspension seat	●
Heated seat	●
Wiper	●
Sprayer f. wiper	●
AUX 1 on Joystick	●
AUX 2 on Joystick	●
Removable front-window	●
Sky light openable	●
Integrated cooling box	●

**WORKING LIGHTS**

Lights – front (LED)	●
Lights – boom (LED)	●
Lights – platform (LED)	●
Lights – back (LED)	●

**ENGINE**

Auto idle	●
Diesel filter	●
DOC	●

**HYDRAULIC SYSTEM**

Swing brake	●
2 speed travel	●
Piping for additional hydraulic function AUX 1	●
Piping for additional hydraulic function AUX 2	●
Hydr. Pre-pressure operating joysticks	●
Mainfilter	●

**SAFETY**

Battery master switch	●
Travel Alarm	●
Warning beacon	●
Camera	●
Handrails	●
Lockable hoods	●
Lockable fuel cap	●

**WORKING EQUIPMENT**

Boom and arm load holding valves with overload indicator	●
Double acting circuit for hydraulic quick coupler with piping	●
Breaker&Shear line proportional on Joystick with piping	●
Rotation line proportional on Joystick with piping	●
Rotation line on Joystick with piping	●
Flow adjustment for attachments	●
Short arm	●

**UNDERCARRIAGE**

Steel tracks 600	●
Holes/loops for fixing	●

Standard equipment ● Special option ●

The standard and special options differ depending on the country in which the crawler excavator is delivered. If you have any questions, please contact your dealer directly.

**SANY – flexible, fast and always there for you**

Rapid assistance, tailored advice and a reliable supply of original parts – that is what we mean by a premium service.



**NSW**



**The added benefits SANY offers you:**

- + Fast supply due to central located parts warehouses
- + More than 15,000 spare parts to make your machine highly reliable
- + Expert knowledge for optimal supply for your machine
- + Thanks to SANY's special training programme, our dealers are always kept up-to-date so that they can face all technical challenges.

**Parts supply – quick and reliable**

With the purchase of a SANY crawler excavator you have made an investment in the future. Fast availability of spare parts is your guarantee of minimal downtimes and failure times.



**Detailed information in black and white**

Handbooks and documents are available for all SANY compact excavators, and these can help you with operation, maintenance, servicing and repairs. These include operating and maintenance instructions and technical specifications.







# THE ALLROUNDER THAT PICKS UP EVERYTHING

The SANY SY215C is a powerful all-rounder which combines flexibility and power. It can therefore perform various tasks in a wide range of applications and its robust design means that it is comfortable even with difficult tasks and tough environments.

## DURABLE AND ROBUST

The SY215C can be used whenever the going really gets tough. This means that it must be able to withstand a great deal. No problem, as with its reinforced, **extremely robust undercarriage** and **particularly clean, robot-welded seams**, the SY215C is exactly the right excavator for hard day-to-day work on construction sites.

## COMFORTABLE WORKSTATION

You know there are good **ergonomics** when you can still concentrate on your work after several hours. No problem in the cockpit of the SY215C because the seat and controls have been **designed for practical requirements**. For example, the additional hydraulic circuits can be operated using the joysticks.

## AGILE POWER

The stable **heavy-duty undercarriage** and its sheer mass provide the SY215C with the stability required to make **quick and powerful operational movements**. The excavator can therefore even tackle large tasks in a short time.

## SAFETY AS A PRODUCTION FACTOR

The clever cab structure provides a clear view of the working area and the **camera supplied as standard** provides a good overview, including of the area behind the excavator. The **overload warning** and the **safety valve** are absolutely essential when the boom is used for lifting. Moreover, when performing maintenance and servicing tasks, handrails and anti-slip tread surfaces provide you with the required stability.

## HIGH QUALITY AND TRIED-AND-TESTED

With its maximum torque of 732 Nm at 1500 rpm, the very strong **six-cylinder Cummins engine** brings an incredible amount of power.

## EFFICIENCY AND POWER

In conjunction with the electronic fuel injection, the **autothrottle function** adjusts the engine speed to the power required. This means that the **smart hydraulic system** reduces the fuel consumption, engine wear and exhaust emissions. In addition, the excavator's **low maintenance requirements and long intervals between maintenance** save operating costs and increase the cost-effectiveness.

## TECHNICAL HIGHLIGHTS

Engine	CUMMINS QSB6.7
Rated power	122 kW / 2 300 rpm
Max. torque	732 Nm / 1 500 rpm
Max. travel speed	6 km/h
Swingspeed	10.7 rpm
Mainpump	2 x variable-piston-pump with electronic positive control
Max. oilflow	2 x 222 l/min

Not all products are available in all markets. As part of our continuous improvement process, we reserve the right to modify specifications and designs without giving prior notice. The figures may contain additional options.

**YELLO EQUIPMENT**

**SANY AUTHORISED DEALER**

P: 1300 093 556

W: YELLOEQUIPMENT.COM

**YELLO**<sup>TM</sup>  
EQUIPMENT