

SY365C

PRODUCT SPECIFICATIONS



YELLO[™]
EQUIPMENT



STANDARD FEATURES

- Powerful, robust and reliable powertrain and hydraulic components for long life in the most demanding applications
 - A high-performance cooling system equipped with electronic control fan clutch provides clean, quiet operation
 - Optimized negative flow control hydraulics improve operating efficiency by up to 5% and fuel efficiency by up to 10%
 - Selectable working modes match machine performance to the application, maximizing productivity and minimizing operating costs
- ➔ Gross Power
205.0 kW / 275 HP
 - ➔ Dig Depth
7290 mm / 23' 11"
 - ➔ Operating Weight
36700 kg / 80,910 lb
 - ➔ Bucket Breakout
192.0 kN / 43,163 lbf

YELLO EQUIPMENT

SANY AUTHORISED DEALER

P: 1300 093 556

W: YELLOEQUIPMENT.COM





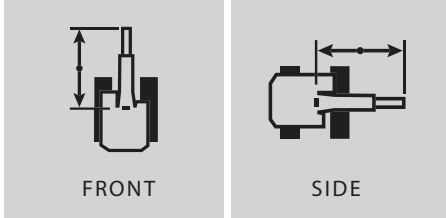
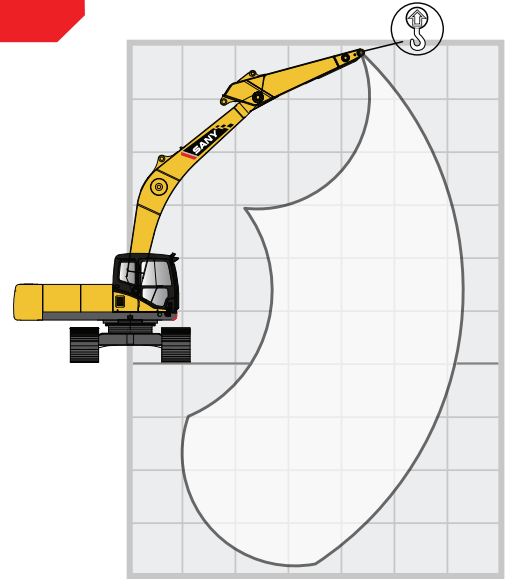







YELLO[™]
EQUIPMENT

SY365C | LIFTING PERFORMANCE



FRONT

SIDE

LOAD RADIUS	3.0 m 9.8 ft		4.5 m 14.8 ft		6.0 m 19.7 ft		7.5 m 24.6 ft		9.0 m 29.5 ft		MAX REACH	
LOAD POINT HEIGHT												
7.5 m 24.6 ft							8223 kg* 18,129 lb*	8223 kg* 18,129 lb*			8230 kg* 18,144 lb*	8230 kg* 18,144 lb*
6.0 m 19.7 ft							8275 kg* 18,243 lb*	8275 kg* 18,243 lb*			7995 kg* 17,626 lb*	7517 kg* 16,572 lb
4.5 m 14.8 ft			11749 kg* 25,902 lb*	11749 kg* 25,902 lb*	10119 kg* 22,309 lb*	10119 kg* 22,309 lb*	8742 kg* 19,273 lb*	8742 kg* 19,273 lb*	7940 kg* 17,505 lb*	6832 kg 15,062 lb	7897 kg* 17,626 lb*	6747 kg 14,875 lb
3.0 m 9.8 ft			15299 kg* 33,728 lb*	15299 kg* 33,728 lb*	11344 kg* 25,009 lb*	11344 kg* 25,009 lb*	9346 kg* 20,604 lb*	8807 kg 19,416 lb	8141 kg* 17,948 lb*	6727 kg 14,830 lb	7850 kg* 17,306 lb*	6354 kg 14,008 lb
1.5 m 4.9 ft			16963 kg* 37,397 lb*	16963 kg* 37,397 lb*	12316 kg* 27,152 lb*	10771 kg 23,746 lb	9846 kg* 21,707 lb*	8557 kg 18,865 lb	8189 kg 18,054 lb	6607 kg 14,566 lb	7713 kg* 17,004 lb*	6230 kg 13,735 lb
0 m 0 ft			17083 kg* 37,662 lb*	17083 kg* 37,662 lb*	12702 kg* 28,003 lb*	10631 kg 23,437 lb	9697 kg 21,378 lb	8375 kg 18,464 lb	8098 kg 17,853 lb	6520 kg 14,374 lb	7887 kg* 17,388 lb*	6356 kg 14,013 lb
-1.5 m -4.9 ft	12852 kg* 28,334 lb*	12852 kg* 28,334 lb*	16154 kg* 35,613 lb*	16154 kg* 35,613 lb*	12366 kg* 27,262 lb*	10537 kg 23,230 lb	9608 kg 21,182 lb	8291 kg 18,325 lb			7927 kg* 17,476 lb*	6785 kg 14,958 lb
-3.0 m -9.8 ft	18272 kg* 40,283 lb*	18272 kg* 40,283 lb*	14325 kg* 31,581 lb*	14325 kg* 31,581 lb*	11179 kg* 24,645 lb*	10554 kg 23,268 lb	8642 kg* 19,052 lb*	8312 kg 18,325 lb			7766 kg* 17,121 lb*	7711 kg 17,000 lb
-4.5 m -14.8 ft	13801 kg* 30,426 lb*	13801 kg* 30,426 lb*	11249 kg* 24,800 lb*	11249 kg* 24,800 lb*	8710 kg* 19,202 lb*	8710 kg* 19,202 lb*					7176 kg* 15,820 lb*	7176 kg* 15,820 lb*

DIMENSIONS

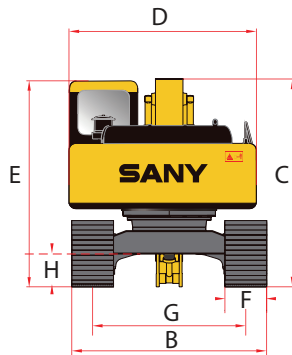
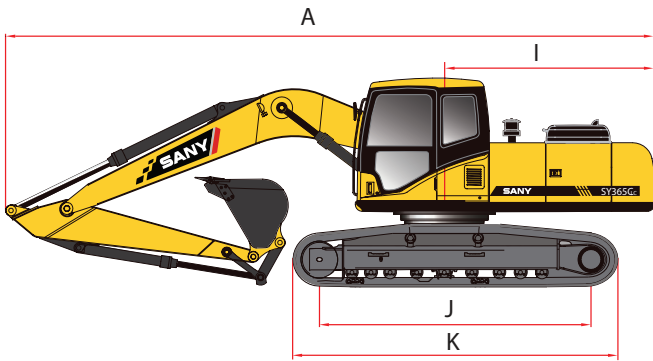

DIMENSIONS

Boom Length	6470 mm	21' 3"
Stick (Arm) Length	3178 mm	10' 5"
A Transport Length	11100 mm	36' 5"
B Transport Width	3390 mm	11' 1"
C Transport Height	3600 mm	11' 10"
D Upper Structure Width	3020 mm	9' 11"
E Cab Height	3140 mm	10' 4"
F Track Width (standard shoe)	800 mm	31"
G Track Gauge	2590 mm	8' 6"
H Ground Clearance	550 mm	22"
I Tailswing Radius	3300 mm	10' 10"
J Track Length on Ground	4140 mm	13' 7"
K Track Length	5055 mm	16' 7"

TECHNICAL SPECIFICATIONS

Operating Weight	36700 kg	80,910 lb
Ground Pressure	48.7 kPa	7.1 psi
Engine	Cummins QSL9 T4F	
Displacement	8.9 L	543.1 in ³
Gross Power	205 kW	275 HP
Hydraulics	Negative Flow Control with Pilot Control	
Main Hydraulic Pump	Axial Piston - Variable Displacement	
Operating Flow(maximum)	740.0 L/min	195.5 gal/min
Operating Pressure(maximum)	34.3 MPa	4975 psi
Power Boost Pressure (maximum)	37.3 MPa	5410 psi
Travel Motor	Axial Piston with Park Brake	
Travel Pressure (maximum)	34.3 MPa	4975 psi
Travel Speeds (maximum)	3.4 / 5.2 km/hr	2.1 / 3.2 mph
Travel Effort (maximum)	214.0 kN	48,109 lbf
Grade Capability(maximum)	35°	
Swing Motor	Axial Piston with Swing Brake	
Swing Pressure (maximum)	27.5 MPa	3989 psi
Swing Speed (maximum)	9.8 RPM	
Undercarriage (standard)	Steel Track	
Track Shoe width (standard)	800 mm	2' 7"
Track Rollers (per side)	9	
Carrier Rollers (per side)	2	

SERVICE REFILL CAPACITIES

Fuel Tank Capacity	540.0 L	142.7 gal
DEF Tank Capacity	38.0 L	10.0 gal
Hydraulic Tank Capacity	340.0 L	89.8 gal
Engine Oil Capacity	29.0 L	7.7 gal
Cooling System Capacity	48.0 L	12.7 gal

WORKING RANGE

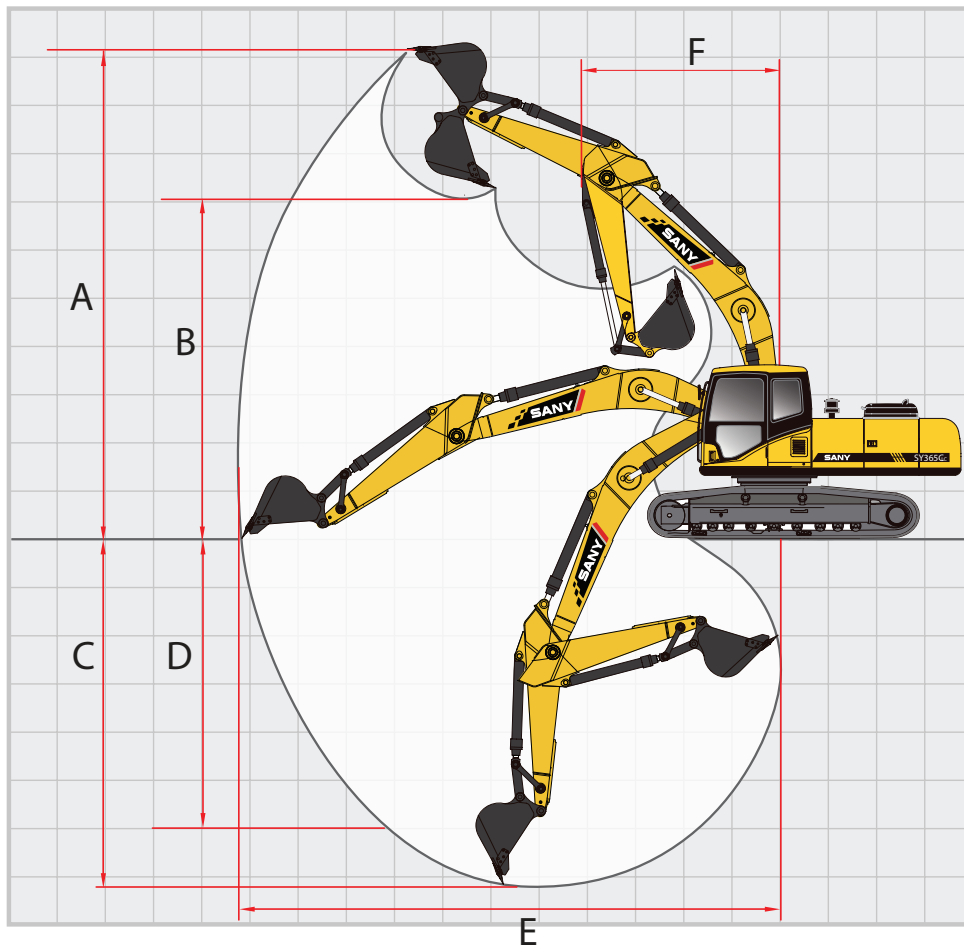

WORKING RANGE

Boom Length	6470 mm	21' 3"
Stick (Arm) Length	3178 mm	10' 5"
A Maximum Digging Height	9820 mm	32' 3"
B Maximum Dumping Height	7150 mm	23' 5"
C Maximum Digging Depth	7290 mm	23' 11"
D Maximum Vertical Wall Digging Depth	6480 mm	21' 3"
E Maximum Reach at Ground Level	11090 mm	36' 5"
F Minimum Swing Radius	4450 mm	14' 7"

DIGGING PERFORMANCE

Boom Length	6470 mm	21' 3"
Stick (Arm) Length	3178 mm	10' 5"
Bucket Breakout Force (ISO)	192.0 kN	43,163 lbf
Stick (Arm) Digging Force (ISO)	168.0 kN	37,768 lbf

YELLO EQUIPMENT

SANY AUTHORISED DEALER

P: 1300 093 556

W: YELLOEQUIPMENT.COM

YELLOTM
EQUIPMENT