

DRUM VIBRATION TECHNOLOGY

- ◆ The use of water wheel type lubrication on the vibratory bearing extends the bearing life up to 5,000 hours.
- ◆ Drum evenness and smoothness meets stringent highway surface work requirements.
- ◆ Road surface clearance height at the edge can be up to 825mm.

ADVANCED HYDRAULIC SYSTEM

- ◆ The closed loop hydraulic system has three filters for greater reliability.

OPERATOR COMFORT AND SAFETY FEATURES

- ◆ Cab mounted on three stage vibration damping mounts
- ◆ Cab climate control
- ◆ Specially designed parking brake system

Leading vibration wheel technology

- ◆ The lubrication device fully lubricates the bearings and shafts. Bearing service life of more than 5000h
- ◆ High flatness, high density, to meet the high-speed road construction. Strict requirements
- ◆ Well compaction approach gap height reaches 825mm

Smart and intelligent control system

- ◆ The control table rotates 90° left and right, which is convenient for well compaction
- ◆ Control saddle box integrated with vibration and driving handle, convenient flexible

Safe and comfortable humanized design

- ◆ ROPS certified cab can effectively guarantee the driver safety of life
- ◆ Three-stage vibration reduction and air conditioning in the cab ensure comfortable work Environment, the driver's ear noise is within 80dB
- ◆ The vibration reduction effect of the cab reaches a good level
- ◆ Designed parking knob and emergency stop button to ensure construction safety

Strong power system

- ◆ Strong power, suitable for various working conditions such as ramp construction
- ◆ Three-stage filtration of oil circuit
- ◆ The engine cover is opened on both sides, and all maintenance points are within easy reach

Advanced Hydraulic System

- ◆ Closed hydraulic system, high efficiency, high reliability

Reliable sprinkler system

- ◆ Two rotomoulding water tanks with a volume of 800L can be filled at one time. It can be constructed normally for more than 5.7 hours
- ◆ Effectively prevent steel wheels from sticking to asphalt
- ◆ Spare sprinkler pump design to ensure smooth construction

RELIABLE OIL-SPRAYING SYSTEM

- ◆ 800L plastic lined water tanks provide water for up to 5.7 continuous hours of work
- ◆ Optimized spray amount prevents asphalt from sticking to drums and limits asphalt cooling.
- ◆ A back-up spray pump for greater reliability

RELIABLE AND EFFICIENT POWER

- ◆ Sufficient power to operate on slopes
- ◆ Three stage fuel filter system
- ◆ Engine cover opens wide to provide easy access for maintenance

EFFICIENT CONTROL SYSTEM

- ◆ The operating controls can swing up to 90° right or left to allow the operator a clear view when working at the road edges.
- ◆ The speed and direction control joystick are integrated for greater control



TECHNICAL PARAMETER

STR30C-8

Technical Parameter of STR30C-8 Tandem Drum Roller

型号 Model		STR30C-8
Weight and Load	Operating Weight(kg)	3000
	Weight at Drum(kg)	1450
	Weight at Rear axle	1550
	Front Drum Static Liner Load(N/cm)	118
	Rear Drum Static Liner Load(N/cm)	126
Compaction	Vibration Frequency(Hz)	55/67
	Nominal Amplitude(mm)	0.5
	Excitation Force(kN)	28/46
	Drum Diameter(mm)	700
	Drum Width(mm)	1200
Maneuver Ability	Drum Edge Thickness(mm)	14
	Travel Speed(km/h)	0~11
	Working Speed(km/h)	0~6
	Theoretical Gradeability Vibratory	30%
	Theoretical Gradeability Non-Vibratory	40%
	Ground Clearance(mm)	240
	Wheelbase(mm)	1700
	Steering Angle(°)	±30
	Swing Angle(°)	± 6
	Min. Turning Outside Diameter(mm)	7050
Engine	Crab Distance(mm)	/
	Brand	YANMAR
	Model	3TNV88-BDTC
	Cooling System	Water Cooling
	Emission	GB 20891-2014 STAGE III
	Rate Speed(rpm)	3000(gross)
	Rated Net Power(kW)	28.1
Capacity	Battery(V×Ah)	12×40
	Water Tank(L)	160
	Fuel Tank(L)	40
	Hydraulic Oil Tank(L)	28

STR30C-8

Tandem Drum Roller STR30C-8 Standard and Optional Configurations

Config	Systems	Description	Quantity	Details	Remarks
Standard Configuration	Main Machine	STR30C-8	1	1.Engine 2.Travel Pump 3.Vibration Pump 4.Travel Motor 5.Vibration Motor 6.Reduction Gears 7.Operating Platform 8.Electrical System	9.Vibratory Drum (Smooth) 10.Front Frame 11.Rear Frame 12.Water-Spraying System 13.Covering Parts 14.Seat
		STR30C-8 Tandem Drum Roller, Standard			
Optional Configuration	Shed (without HVAC)	Shed (without HVAC)	1	Low cost	Substitute operating platform allowed

STR30C-8

Dimensions of STR30C-8 Tandem Drum Roller

主要尺寸 Size Code	STR30C-8
A (mm)	1700
B (mm)	1280
C (mm)	550
D (mm)	700
H (mm)	/
H2 (mm)	2560
K (mm)	240
L (mm)	2550
O (mm)	40
W (mm)	1200

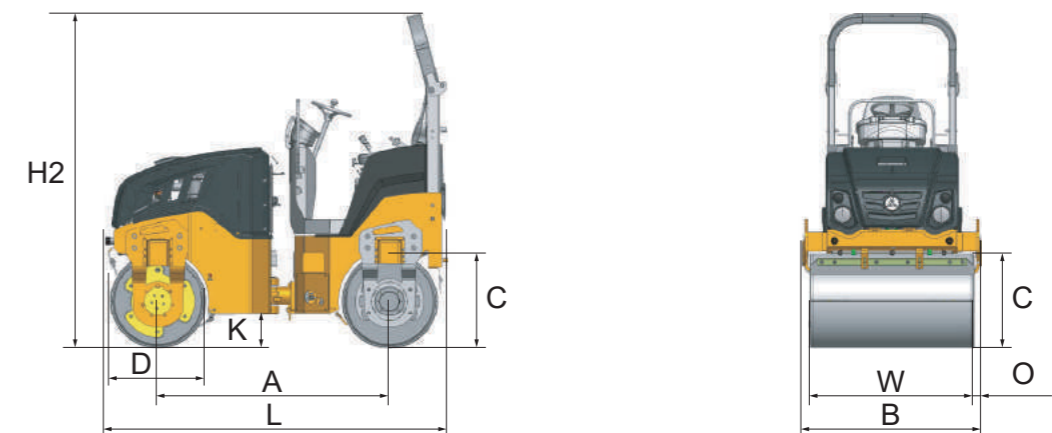

YELLO EQUIPMENT

SANY AUTHORISED DEALER

P: 1300 093 556

W: YELLOEQUIPMENT.COM

YELLO™
EQUIPMENT

SANY®
QUALITY CHANGES THE WORLD.