



Higher compaction efficiency

- ◆ The exciting force is 10% higher than similar models in the industry. Operational efficiency increased by 16.7%

Longer service life of the whole machine

- ◆ Original rat bag type lubricating device fully lubricates bearings, bearings. Service life of more than 5000h
- ◆ Double filtration of air intake at the high position of the engine, and three-stage filtration of the oil circuit

Safer humanised design

- ◆ Original rat bag type lubricating device fully lubricates bearings, bearings. Service life of more than 5000h
- ◆ Double filtration of air intake at the high position of the engine, and three-stage filtration of the oil circuit

Safer humanised design

- ◆ The cab is installed on the shock absorbing bracket
- ◆ Cab temperature can be controlled
- ◆ Operator control has been reduced

HIGH EFFICIENCY

- ◆ 10% greater exciting force than other products in the same category resulting in 16.7% greater production.

EXTENDED LIFE TIME

- ◆ The use of water wheel type lubrication on the vibratory bearing extends the bearing life up to 5,000 hours.
- ◆ Double filtration of engine high intake air, the hydraulic system contains three stage filtration.

OPERATOR COMFORT

- ◆ Cab mounted on vibration damping mounts
- ◆ Cab temperature control
- ◆ Operator control forces have been reduced

SAFETY FEATURES

- ◆ Rounded bumpers front and rear
- ◆ Large rear glass and sloped hood for greater visibility

TECHNICAL PARAMETERS

SSR120C-10

SSR120C-10 Single Drum Roller Technical Parameters

型号 Model		SSR120C-10
Weight and Load	Operating Weight(kg)	12000
	Weight at Drum(kg)	7000
	Weight at Rear axle(kg)	5000
	Drum Static Linear Load(N/cm)	329
Compaction	Vibration Frequency (Hz)	32/36
	Nominal Amplitude(mm)	1.8/0.9
	Centrifugal force(kN)	280/178
	Drum Diameter(mm)	1500
	Drum Width(mm)	2130
	Drum Edge Thickness(mm)	25
Maneuver Ability	Travel Speed(km/h)	0~6.0
		0~7.5
		0~8.5
		0~12.5
	Gradeability	50% / 53%
	Ground Clearance(mm)	480
	Wheelbase(mm)	2868
	Steering Angle(°)	±35
	Swing Angle(°)	±12
	Min. Turning Outside Diameter(mm)	11600
Tires	23.1-26-12PR	
Engine	Brand	DONGFENG CUMMINS
	Model	QSB3.9-C125-30
	Emission	NR3
	Rated Power(kW)	93
Capacity	Battery(V×Ah)	24×120
	Fuel Tank(L)	250
	Hydraulic Oil Tank(L)	100

SSR120C-10

Single Drum Roller SSR120C-10 Standard and Optional Configurations

Config	Systems	Description	Quantity	Details	Remarks
Standard Configuration	Main Machine	SSR120C-10	1	1.Engine 2.Travel Pump 3.Vibration Pump 4.Travel Motor 5.Vibration Motor 6.Reduction Gears 7.Operating Platform 8.Vibratory Drum (Smooth) 9.Electrical System	10.Operating System 11.Front Frame 12.Rear Frame 13.Covering Part 14.Rear Axle Assembly 15.Center Articulated Frame 16.Cab+A/C
		SSR120C-10 Single Drum Roller, Standard			
Optional Configuration	Shed	Shed	1	Low Cost	
	Vibratory Drum with Welded pad foot	Drum with Welded pad foot	1	Vibratory drum with welded pad foot, which cannot be removed, suitable for compaction of clay, semi-clay, rocks, gravels, expansive soil, and coal cinder base	
	Vibratory Drum with Assembled pad foot	Drum with Assembled pad foot	1	Vibratory drum with assembled pad foot, which can be removed to form a smooth drum; suitable for compaction of clay, semi-clay, rocks, gravels, expansive soil, and coal cinder base	

SSR120C-10

Dimensions of SSR120C-10 Single Drum Roller

Size Code	SSR120C-10
A(mm)	2868
W(mm)	2285
L(mm)	5775
D(mm)	1500
H(mm)	3225
B(mm)	2130
K(mm)	480

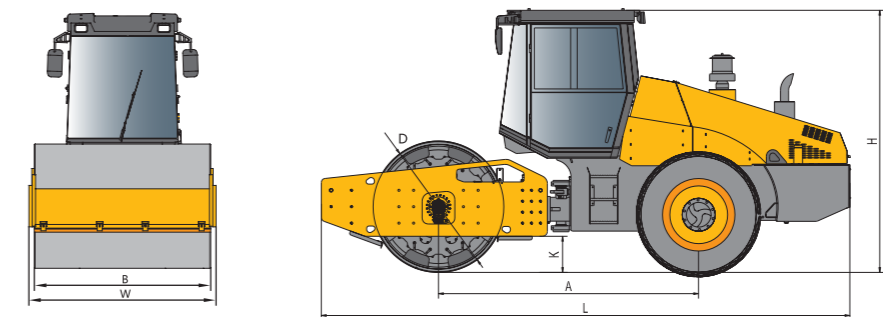

YELLO EQUIPMENT

SANY AUTHORISED DEALER

P: 1300 093 556

W: YELLOEQUIPMENT.COM

YELLO™
EQUIPMENT

SANY®
QUALITY CHANGES THE WORLD.