

YELLOTM
EQUIPMENT

SCAN
QR CODE FOR
PRODUCT INFO

POWERFUL ALL-ROUNDER

MORE POWERFUL.
MORE ROBUST.
FASTER.



CONSTRUCTION MACHINERY



WHEEL LOADER
SW305K **SANY**
Quality Changes the World

Engine
Deutz TCD 6.1 L6
Rated power
129 kW
Bucket capacity
2,3 m³
Operating mass
14500 kg

SANY

For challenging tasks, you need a first-class partner

Quality comes from experience. And from new ideas. This is why we combine these two crucial factors at SANY. This is because we are one of the leading producers, having sold more than **450 000** excavators **worldwide**. This means that you can always rely on sophisticated products that have been tried and tested in practice. An impressive **5–7%** of our annual turnover is dedicated to research and development. This is why we give you not only our word, but also our extraordinary **four-year warranty** as a guarantee of how powerful and robust our products are.

450 000

EXCAVATORS SOLD
WORLDWIDE

5–7%

TURNOVER FOR RESEARCH
AND DEVELOPMENT

FOUR-YEAR WARRANTY*

Quality Changes the World

* Applicable in certain markets; please check with your local dealer.



SW305K HARD FACTS

Transport height
3 405 mm

Transport length
7 518 mm

Max. travel speed
38 km/h

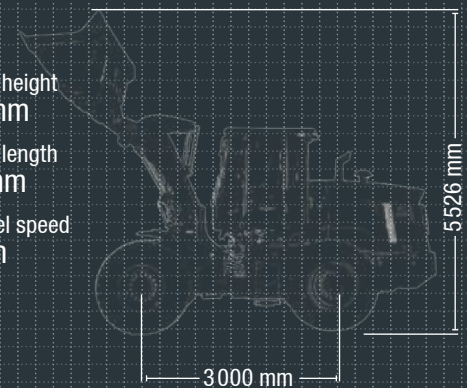



BOTH AN ALL-ROUNDER AND A SPECIALIST

The new SANY SW305K wheel loader is designed entirely for productivity. With its heavy-duty frame design, it can easily withstand the toughest demands and is a real powerhouse wherever it's used. Whether as an all-rounder, handling material or working in applications equipped with specific attachments – you can be certain that the SW305 will always deliver maximum safety and performance. Its exemplary strong breakaway forces and large tipping loads, together with its many automatic working processes, form the basis of its high productivity.

TOP PROPERTIES

ECONOMY

COST-EFFECTIVE SAVINGS

The powerful Deutz Stage V common rail diesel engine impresses users with its high performance and low fuel consumption. This is partially thanks to the electronic engine control system (EMR) with intelligent link to the drive management and the perfectly coordinated automatic powershift transmission. Equipped with four forward gears and three reverse gears, transmission shutdown and a kickdown function. It also offers savings thanks to its compliance with the EU Stage V emission standard with the addition of AdBlue (SCR) and its diesel particulate filter (DPF).

QUALITY

Optimal framework – moving heavy loads requires a foundation up to the job. The SW305K's robust, heavy-duty frame design means that the machine can cope with the most demanding operating conditions.

DIMENSIONS

Show your size – the large-sized articulated joint with the installed high-strength tapered roller bearing is designed for the greatest loads.

USER EXPERIENCE

Developed for operators – the air-sprung Grammer driver's seat, with its high backrest and many individual adjustment options, offers excellent seating comfort.



SAFETY

A clear view – the 360° camera system with a reversing alarm means that the machine is convenient and, above all, safe to operate with an unrestricted all-round view.

COMPONENTS

Quality is what drives us forward – equipped with a state-of-the-art, six-cylinder common rail diesel engine from Deutz, the wheel loader provides a powerful 129 kW performance and a maximum torque of 880 Nm at 2200 rpm.

ECONOMY

Shorter cycle times – the powerful load-sensing hydraulic system enables the attachments to respond optimally and thereby improves the lifting and lowering speed of the lifting gear.

ECONOMY

Impressive efficiency

The speed of the fan blade is controlled according to the temperature. As a result, noise emissions and fuel consumption are reduced. To ensure that the radiator does not get clogged in extreme working conditions and is able to reliably perform its function, it is automatically cleaned by the reversible fan blade. Reverse operation can be set periodically and, accordingly, the radiator cleaning process can be adapted to the outside conditions.

The effective vibration damping system ensures faster driving and that less material is lost. This system minimises pitching movements from the machine and therefore leads to increased productivity.

COMPONENTS

**PERFECTLY EQUIPPED
DOWN TO THE LAST DETAIL**

For all of the important components, SANY only uses tried-and-tested parts from brand manufacturers:

Load-sensing main hydraulic pump from Rexroth with a steering and loading hydraulic pump including a third control circuit as standard

Automatic Ergopower powershift transmission from ZF for maximum ease of shifting in automatic or manual mode

Low-maintenance, heavy-duty axles from ZF with multi-disc brakes running in oil and engageable self locking differential on the front axle



Perfectly adapted kinematics

The Z-kinematics provide full power exactly where it's needed – at the bucket. This ensures strong breakaway forces, as well as quick loading and emptying. The powerful load-sensing system from Rexroth with a steering and loading hydraulic pump has a third control circuit as standard, which is controlled using a single lever control with sliders.

For example, this can be used to directly connect and operate a hydraulic quick-coupler line. The practical float position enables additional applications and more efficient work, for instance when making surfaces level or operating sweeping devices. The safety valves offer extra safety by ensuring that the lifting gear does not lower under load.

EFFICIENCY, COST-EFFECTIVENESS AND USER EXPERIENCE



Absolute reliability – for peace of mind!

SANY's four-year warranty* gives you the assurance that you can fully count on your equipment.

* With participating partners

USER EXPERIENCE

Designed to be straightforward

Operators can automatically apply many routine processes, saving time while also leading to increased precision and productivity. For example, this includes resetting the bucket, which automatically moves the bucket back to the loading position. Everyday work is also made easier by the automatic loading functions and faster loading procedures. This is also true for the speed of the loading hydraulic system, which can be individually adjusted – allowing operators to adjust the lifting, filling and emptying speeds.



USER EXPERIENCE

COMFORTABLE AT FIRST GLANCE

As soon as you safely and comfortably enter the spacious, ROPS/FOPS-certified cab, it's clear that the cockpit is entirely tailored to the comfort and work ergonomics of the driver. A windscreen that extends far down provides an excellent view of the front wheels and the outside edges of the bucket. The operator's field of vision is further extended by the 360° camera system that provides a maximum all-round view in any working situation.

The operator also has a clear view of all important information – the 7" touchscreen display in the cockpit has a generously sized display and an intuitive user interface. For even greater comfort, the machine has an air-sprung driver's seat, height-adjustable armrests for operating the joystick without tiring, excellent noise reduction in the cab with a sound level of just 71 dB(A), a USB port and keyless access.



SAFETY

JUST IN CASE

The cab combines maximum protection for the operator with a high level of comfort. The stable design is ROPS/FOPS-certified and mounted on silent blocks filled with silicone oil – which considerably reduces vibrations within the cab.

If there are faults in the drive unit, the equipment can be safely discharged using the emergency lowering function.

SAFETY

Good lighting for good visibility

If it's getting late or you're working in dark buildings, four LED spotlights ensure that the work area is well lit. Their advantages are that they are low-maintenance, they consume little energy and they have a „leaving home“ function. In addition, four cameras positioned all around provide a 360° panoramic image with maximum visibility and therefore ensure the highest possible active safety. The image is shown in high resolution on the monitor in the driver's cab.



Our highlights – the added benefits SANY offers you:

- + Particularly powerful wheel loader
- + Spacious, ROPS/FOPS-certified cab
- + Hydraulically driven reversible fan
- + Third hydraulic function for proportional control using joystick
- + Main components from renowned manufacturers
- + Comprehensive standard features



QUALITY

Setting standards for durability

The heavy-duty frame design is built for durability. With a robust design and precision-crafted, it is built for use over many operating hours. Likewise, the generously sized articulated bearing is designed for a long service life. Its high-strength tapered roller bearing can withstand the greatest loads.



TECHNICAL SPECIFICATIONS

ENGINE

Model	Deutz TCD 6.1 L6
Type	6-cylinder with common rail injection and water cooling
Emission standard	Stage V
Rated power ISO/TR 14396	129 kW / 2200 rpm
Displacement	6,057 l
Exhaust treatment	SCR / DPF

ELECTRICS

Battery	1 × 12 V / 120 Ah
Alternator (capacity)	100 A

TRANSMISSION

Transmission type	Hydrodynamic
Performance regulation	Automatic
Gears / Forward/reverse	4 / 3
Forward/reverse	Electr. toggle switch/steering column
Max. ground speeds	1st gear : 7 km/h 2nd gear : 14 km/h 3rd gear : 27 km/h 4th gear : 38 km/h

HYDRAULIC SYSTEM

Main pump	Load-sensing axial piston pump
Max. oil flow	220 l/min
Relief valve (working hydraulic)	270 bar
Relief valve (steering)	210 bar

SERVICE FILLING QUANTITIES

Fuel tank	227 l
Engine oil	15.5 l
Front axle	34.8 l
Rear axle	34.8 l
Gearbox	50 l
Hydraulic system	128.7 l
Engine coolant	33 l

OPERATING MASS

Operating mass	14616 kg
----------------	----------

STEERING

Steering type	Articulated
Total steering angle	40°
Outer tyres turning radius	5382 mm
Outer bucket turning radius	5969 mm

TYRES

Dimensions	20.5 R25
------------	----------

BRAKES

Service brake	Hydraulic multi-disc brake in oil both on both axles, acts on all wheels.
Parking brake	Electrohydraulic parking brake

AXLES

Type	Heavy duty; planetary drive on every wheel; oscillating axle (rear)
Angle of oscillation	24°
Differential	Manually engaged self locking differential 100% on the front axle

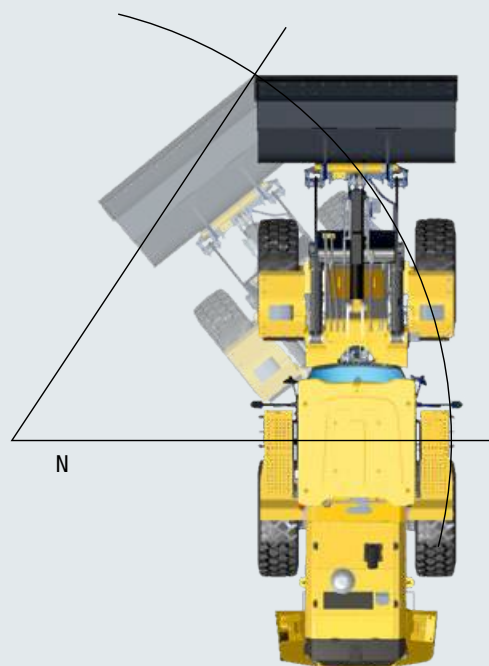

DIMENSIONS (TRANSPORT)

A	Transport length (transport position)	7518 mm
B	Transport width	2545 mm
C	Transport height	3405 mm
D	Tyre width	2045 mm
E	Transport width (tyres)	2476 mm
F	Wheel base	3000 mm
G	Ground clearance	407 mm

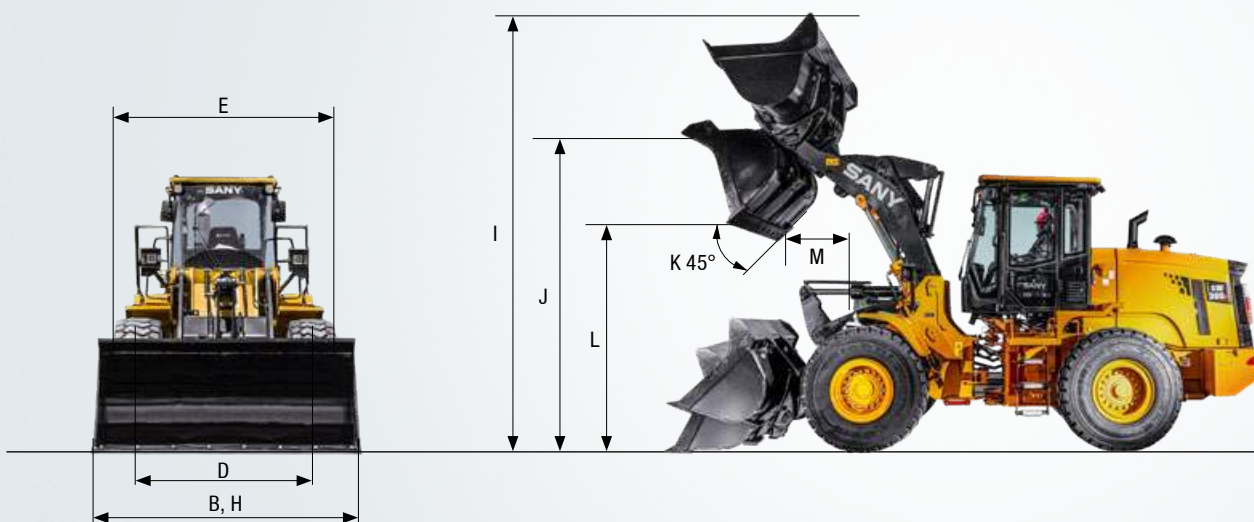
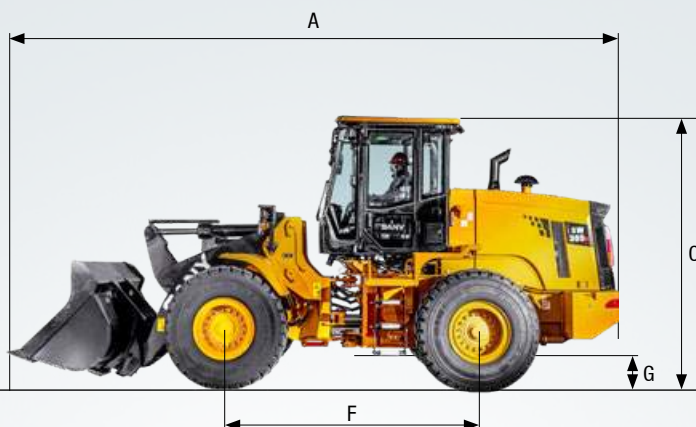

ATTACHMENTS

Bucket capacity (SAE)	2.3 m ³
H Bucket width	2545 mm
I Max. height	5526 mm
J Heights to hinge point	3845 mm
K Dump angle	45°
L Dump height	2689 mm
M Reach fully raised	993 mm
N External bucket turning radius	5969 mm
Bucket weight	990 kg
Bucket static tipping load, straight	8899 kg
Bucket static tipping load, full turned	7714 kg
Breakout force	133 kN
Transport length incl. attachment	7518 mm

Simply more

The new SW305K already comes with a number of features ex-works for improved comfort, greater safety and increased productivity. This includes vibration damping, bucket resetting, adjustable lifting and emptying speeds and the float position.



COMFORT / CABIN

Mechanical suspension seat with adjustable armrests	●
Air-sprung heated seat with adjustable armrests	●
Automatic climate control system*	●
Openable right-hand side window	●
Adjustable steering column	●
12 V socket	●
Reading light	●
7" touchscreen display	●
2 outside and 1 inside rear mirror	●
Panoramic camera system	●
Radio with USB port	●
Drinks holder	●
Document compartment	●
Sun visor	●
Rubber floor mat	●
ROPS/FOPS-certified	●

DRIVE TRAIN: DIESEL ENGINE

Cyclonic air filter	●
Air preheating	●
Fuel prefilter with water separation	●
Temperature-dependent reversible cooling fan	●

ELECTRICAL SYSTEM

Headlight with high and low beam	●
2 work lights on the cab roof	●
Reversing alarm and rotating beacon	●
Battery main switch	●
Windscreen and rear window wiper	●
Engine start-up protection when the gear is engaged	●
Encoded start-up protection	●

HYDRAULIC SYSTEM

Load-sensing system with variable pump power	●
Electrohydraulic single lever control (FNR + KD + third control circuit on roller)	●
Preparation of hydraulic quick-coupler line with lines and actuation	●
Automatic bucket positioning	●
Vibration damping system	●
Sight glass for oil level check	●

BRAKE SYSTEM

Dual-circuit brake system	●
Two brake pedals	●
Electrohydraulic parking brake	●

Standard equipment ● Special option ●

The standard and special options differ depending on the country in which the wheel loader is delivered. If you have any questions, please contact your dealer directly.

* The air conditioner contains fluorinated greenhouse gases: Refrigerant type: HFC-134a, Global warming potential: 1 430, Quantity: 0.85 kg, CO₂e: 1.22 t

Parts supply – fast and reliable

By purchasing a SANY wheel loader, you have invested in the future. Fast availability of spare parts is your guarantee of minimal downtimes and failure times.

A SERVICE YOU CAN RELY ON

Just as we do with our wheel loaders, we demand high quality and reliability of our service products. This underlines our equipment's performance in terms of their durability and their excellent price-performance ratio. After all, maintenance is

crucial for efficiency, cost-effectiveness and safety. Your SANY dealer is happy to help you with a comprehensive range of services to ensure that your machine continues operating efficiently in the long term.

SANY – flexible, fast and always there for you

Rapid assistance, tailored advice and a reliable supply of original parts – that is what we mean by a premium service.



NSW



The added benefits SANY offers you:

- + Fast supply due to central located parts warehouses
- + More than 15 000 spare parts for high machine reliability
- + Expert knowledge for optimal supply for your machine
- + Thanks to SANY's special training programme, our dealers are always kept up-to-date so that they can face all technical challenges.

Detailed information in black and white

Handbooks and documents are available for all SANY wheel loaders; these can help you with operation, maintenance, servicing and repairs. These include operating and maintenance instructions and technical specifications.



HIGHLIGHTS **SW305K**

EFFICIENCY MEETS VERSATILITY

The new SANY SW305 wheel loader takes productivity to the next level. With its powerful Deutz common rail diesel engine and the robust heavy-duty frame design, it's the ideal choice wherever power and reliability are required. Its signature features are its strong breakaway forces and large tipping loads. What's more, with its many options for attachments, this powerhouse is a multifunctional machine that can handle a wide range of wheel loader tasks with flying colours.



OPTIMAL FRAMEWORK

Its **long service life** under even the toughest conditions is ensured by the **heavy-duty frame design** and the **HD axles from ZF**, for example.

SHOW YOUR SIZE

The SW305 is also optimally equipped for large tasks. The **Z-kinematics** provide full power to the bucket and ensure **strong breakaway forces** and **quick loading and emptying times**.

DEVELOPED FOR OPERATORS

Spacious, clearly arranged, ergonomic – the **driver's cab mounted on silent blocks** with many comfort features offers a pleasant and safe working environment.

A CLEAR VIEW

Four cameras provide a 360° panoramic image with maximum visibility. In poor visibility, support is also provided by the **four low-maintenance and powerful LED spotlights**.

QUALITY IS WHAT DRIVES US FORWARD

High-powered and with a high torque – the **Deutz 6-cylinder diesel** and the **automatic Ergopower powershift from ZF** enable users to quickly reposition and work with the machine.

SHORTER CHARGING CYCLES

The **intelligent control system for the hydraulic power** ensures that the pump only conveys the volume flow that is actually needed by the active consumers. This not only saves fuel but also enables faster work progress, for example thanks to an **optimised lifting and lowering speed for the lifting gear**

TECHNICAL HIGHLIGHTS

Engine	Deutz TCD 6.1 L6
Rated power	129 kW / 2 200 rpm
Bucket capacity	2,3 m ³
Max. travel speed	38 km/h
Total steering angle	40°
Main pump	Load-sensing axial piston pump
Max. oil flow	220 l/min

Not all products are available in all markets. As part of our continuous improvement process, we reserve the right to modify specifications and designs without giving prior notice. The figures may contain additional options.

YELLO EQUIPMENT

SANY AUTHORISED DEALER

P: 1300 093 556

W: YELLOEQUIPMENT.COM

YELLOTM
EQUIPMENT